



<b>UK EPR</b>		
	Title: Overview of the UK EPR™ GDA Submission	
	<b>UKEPR-0013-001 Issue 00</b>	
Total number of pages: 31		Page No.: I / II
Author: K. ARDRON		
Name/Initials <i>pp</i>  Date 08-10-2009		
Approved for EDF by: A. PETIT		Approved for AREVA by: C. WOOLDRIDGE
Name/Initials  Date 08-10-2009		Name/Initials <i>C. Wooldrige</i> Date 08-10-2009

### REVISION HISTORY

Issue	Description	Date
00	First issue	08-10-2009

<b>UK EPR</b>		
	Title: Overview of the UK EPR™ GDA Submission	
	<b>UKEPR-0013-001 Issue 00</b>	Page No.: II / II

**Copyright © 2009**

**AREVA NP & EDF  
All Rights Reserved**

This document has been prepared by or on behalf of AREVA NP and EDF SA in connection with their request for generic design assessment of the EPR™ design by the UK nuclear regulatory authorities. This document is the property of AREVA NP and EDF SA.

Although due care has been taken in compiling the content of this document, neither AREVA NP, EDF SA nor any of their respective affiliates accept any reliability in respect to any errors, omissions or inaccuracies contained or referred to in it.

All intellectual property rights in the content of this document are owned by AREVA NP, EDF SA, their respective affiliates and their respective licensors. You are permitted to download and print content from this document solely for your own internal purposes and/or personal use. The document content must not be copied or reproduced, used or otherwise dealt with for any other reason. You are not entitled to modify or redistribute the content of this document without the express written permission of AREVA NP and EDF SA. This document and any copies that have been made of it must be returned to AREVA NP or EDF SA on their request.

Trade marks, logos and brand names used in this document are owned by AREVA NP, EDF SA, their respective affiliates or other licensors. No rights are granted to use any of them without the prior written permission of the owner.

**Trade Mark**

EPR™ is an AREVA Trade Mark.

**For information address:**



AREVA NP SAS  
An AREVA and Siemens Company  
Tour AREVA  
92084 Paris La Défense Cedex  
France



EDF  
Division Ingénierie Nucléaire  
Centre National d'Équipement Nucléaire  
165-173, avenue Pierre Brossolette  
BP900  
92542 Montrouge  
France

**TABLE OF CONTENTS**

1.	INTRODUCTION	2
2.	BASIC EPR™ FACTS	2
2.1.	EPR™ Description	2
2.2.	Plant Design	4
2.2.1.	Plant Layout	4
2.2.2.	EPR™ Nuclear Systems	6
2.2.3.	Reactor Coolant System	7
2.2.4.	Reactor Core	10
2.2.5.	Systems	12
2.2.6.	Instrumentation & Control System	15
2.2.7.	Electrical Power System	16
3.	NUCLEAR SAFETY	16
3.1.	Safety Design	16
3.2.	Defence-In-Depth	16
3.3.	Safety Analysis	18
3.4.	Dose Targets and Legal Limits	20
4.	OPERATION AND MAINTENANCE	21
4.1.	Normal Operation	21
4.2.	Preventive Maintenance	21
5.	SPENT FUEL AND RADIOACTIVE WASTE MANAGEMENT INCLUDING DECOMMISSIONING	22
6.	OTHER ENVIRONMENTAL IMPACTS	24
6.1.	IMPACTS ON TERRESTRIAL ECOSYSTEM	25
6.2.	IMPACTS ON AQUATIC ECOSYSTEM	27
6.3.	IMPACT ON DESIGNATED AREAS, SENSITIVE HABITATS AND PROTECTED SPECIES	28
6.4.	IMPACT ON SOCIO-ECONOMICS	28
7.	DESCRIPTION OF SUBMISSION DOCUMENTS	28
8.	HOW TO FIND INFORMATION IN THE SUBMISSION	29
9.	HOW TO COMMENT	29

## 1. INTRODUCTION

This document is an overview of the UK EPR™ GDA submission (at September 2009). The purpose of the submission is to allow the UK Regulatory Authorities to carry out a detailed assessment of the nuclear safety and environmental impact of the UK EPR™ design under their Generic Design Assessment (GDA) process. The GDA submission comprises the Safety, Security and Environmental Report (SSER) for the proposed UK EPR™ design, supplemented by a number of supporting documents, providing further information in a number of areas. The SSER comprises a Pre-Construction Safety Report (PCSR) containing nuclear safety aspects of the UK EPR™ design and a Pre-Construction Environmental Report (PCER) describing the environmental impact of the reactor, including both nuclear and non-nuclear discharges and waste production. The security of the plant against deliberate malevolent acts is discussed in separate submissions which are outside the scope of these documents.

The overview given below provides a summary of the main design features of the UK EPR™ reactor and the nuclear safety case and environmental impact assessment. Where appropriate, reference is made to the PCSR and PCER chapters for more detailed information. Information is also given on the structure of the GDA submission, how to find information and how to comment on the submission.

The EPR™ design has already obtained construction licences from safety authorities in Finland and France and is currently in the process of obtaining Design Certification and several Combined Operating Licences (COL) in the USA. The UK EPR™ design submitted in August 2007 for Generic Design Assessment is intended to be the same as the reference EPR™ plant being built at Flamanville in France.

[{A summary of the assessment of overseas regulators of the EPR™ design can be found in Sub-chapter 1.5 of the UK EPR Pre-Construction Safety Report}.](#)

## 2. BASIC EPR™ FACTS

### 2.1 EPR™ DESCRIPTION

The UK EPR™ reactor is a Pressurised Water Reactor (PWR) with a rated thermal power of 4500 MW and an electrical power output around 1630 MW depending on conventional island technology and heat sink characteristics.

The EPR™ evolutionary design is based on experience gained many years of operation of Light Water Reactors (LWR) worldwide, primarily the most recent European PWRs (the N4 and KONVOI reactors operating in France and Germany respectively). The EPR™ primary system design, loop configuration, and main components are similar to those of currently operating PWRs, giving a proven foundation for the design.

The EPR™ design complies with safety requirements formulated by the French and German nuclear safety authorities for the next generation of nuclear reactors.

Relative to current generation PWRs, the EPR™ design philosophy has the following objectives:

- to reduce core damage frequency,

- to reduce the frequency of large releases of radioactivity,
- to mitigate severe accidents,
- to protect critical systems from external events such as aircraft impact,
- to achieve an improved plant availability factor (above 90%),
- to give extended flexibility for different fuel cycle lengths and capability for load following,
- to give increased saving on uranium consumption per MWh produced,
- to achieve further reduction in long-lived actinides generation per MWh through improved fuel management,
- to provide a plutonium recycling capability with a core able to accommodate up to 50% of MOX1 fuel assemblies.

The EPR™ operating design life of 60 years, reduced fuel consumption and waste production per unit of energy output, contribute to long term sustainability. Economic viability is provided by the fact that:

- the investment and operating costs are balanced by a large power output;
- the large core with a low power density provides an efficient use of fuel;
- the high steam pressure leads to a high net efficiency;
- high availability is ensured by the use of proven technology and KONVOI design features which allow short outages.

EPR™ plants are currently under construction in Finland, France and China.

The EPR™ reactor is a four-loop PWR whose Reactor Coolant System (RCS) comprises a Reactor Pressure Vessel (RPV) containing the fuel assemblies, a pressuriser (PZR) including control systems to maintain system pressure, one Reactor Coolant Pump (RCP) per loop, one steam generator (SG) per loop, associated piping, and related control and protection systems. These components are standardised for all EPR™ projects.

In PWRs ordinary (light) water is utilised to remove the heat produced inside the reactor core by the thermal nuclear fission. The water in the core acts to slow down (moderate) the neutrons (the elementary constituents of atomic nuclei that are released in the nuclear fission process). Slowing down neutrons is necessary to sustain the nuclear chain reaction (i.e. to break down the fissile atomic nuclei). The heat produced inside the reactor core is transferred to the turbine through the steam generators. Only heat energy is exchanged between the reactor cooling circuit (primary circuit) and the secondary circuit used to feed the turbine. No exchange of cooling water takes place.

In the RCS, the primary cooling water is pumped through the reactor core and the tubes inside the SGs, in four parallel closed loops, by four RCPs powered by electric motors. The reactor operating pressure and temperature are such that the cooling water does not evaporate in the primary circuit but remains in the liquid state, increasing its cooling effectiveness. A PZR, connected to one of the coolant loops is used to control the pressure in the RCS. Feedwater entering the secondary side of the steam generators absorbs the heat transferred from the primary side and evaporates to produce saturated steam. The steam is dried inside the steam generators then delivered to the turbine. After exiting the turbine, the steam is condensed and returned as feedwater to the SGs. A generator, driven by the turbine, generates electricity. The system is shown schematically in Figure 1.

---

<sup>1</sup> Note with some plant modifications, 100% of the core could be composed of MOX fuel assemblies.

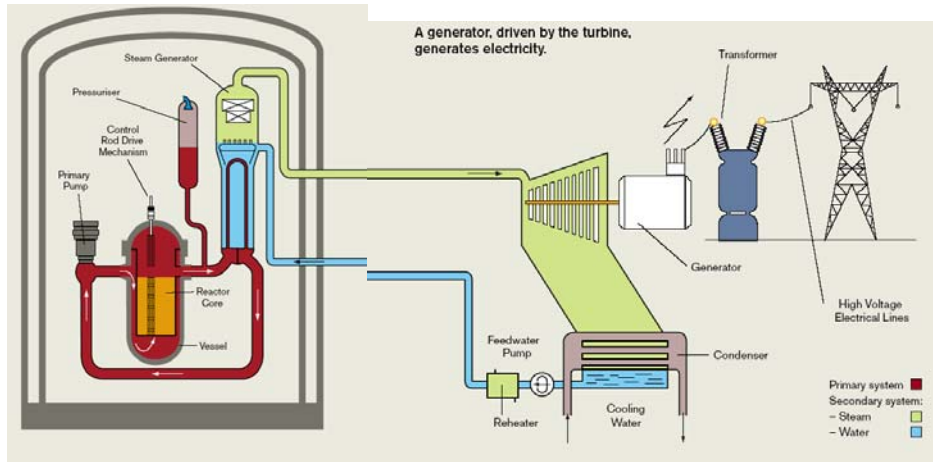

Figure 1: Pressurised Water Reactor

**2.2 PLANT DESIGN**

**2.2.1 Plant Layout**

The plant layout is shown in Figures 2 and 3. Referring to the figures, the EPR™ plant comprises a Reactor Building [1], a Fuel Building [2], four Safeguard Buildings [3], two Diesel Buildings [4], a Nuclear Auxiliary Building [5], a Waste Building [6] and a Turbine Building [7].

{A description of the EPR™ buildings and plant layout can be found in Sub-chapter 1.2 of the UK EPR Pre-Construction Safety Report}.

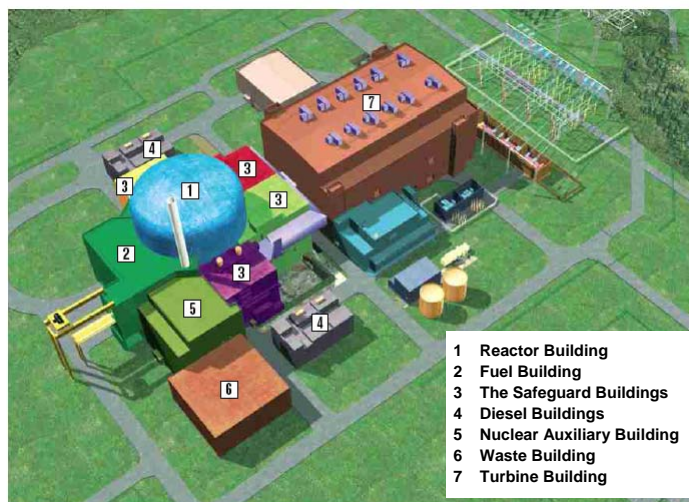

Figure 2: Typical plant layout

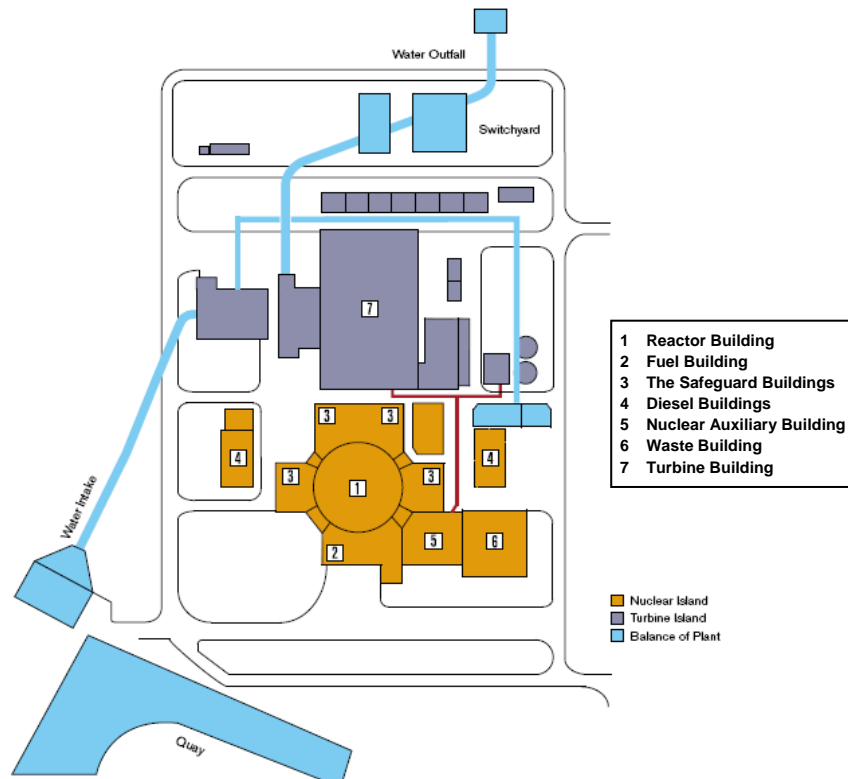

Figure 3 – Plan of typical plant layout

The Reactor Building is surrounded by the four Safeguard Buildings and the Fuel Building. The internal structures and components within the Reactor Building, Fuel Building, and two Safeguard Buildings (including the plant Main Control Room) are protected against aircraft hazard and external explosions. The other two Safeguard Buildings are not protected against aircraft hazard; however, they are geographically separated by the Reactor Building, which prevents both buildings from being simultaneously affected by such a hazard.

*[1] Reactor Building*

The Reactor Building, located in the centre of the Nuclear Island, houses the main components of the Nuclear Steam Supply System (NSSS). Its main function is to prevent the release of radioactive materials into the environment under all circumstances, including possible accident conditions. It consists of a cylindrical pre-stressed concrete inner containment with a metallic liner, surrounded by an outer reinforced concrete shell. The primary system components are arranged within shielded areas within the reactor building.

*[2] Fuel Building*

The Fuel Building, located on the same basemat that supports the Reactor Building and the Safeguard Buildings, houses an interim fuel storage pool for fresh and spent fuel and associated fuel handling equipment.

*[3] The Safeguard Buildings*

The four Safeguard Buildings house key safeguard systems and their support systems. These safeguard systems are divided into four trains each of which is housed in a separate division located in one of the four Safeguard Buildings.

The Main Control Room is located in one of the Safeguard Buildings.

*[4] Diesel Buildings*

The two Diesel Buildings house the four Emergency Diesel Generators, two Station Black-out Diesel Generators and their support systems that are used to supply electricity to the safeguard systems in the event of a complete loss of electrical power. The physical and geographical separation of these two buildings provides additional protection.

*[5] Nuclear Auxiliary Building*

The Nuclear Auxiliary Building is located on a basemat which is separate from that supporting the Reactor Building. All air-exhausts from the radiological controlled areas are routed, collected and controlled within the Nuclear Auxiliary Building prior to release through the stack.

*[6] Waste Building*

The Waste Building is used for the collection, storage, treatment and disposal of liquid and solid radioactive waste and is adjacent to the Nuclear Auxiliary Building.

*[7] Turbine Building*

The Turbine Building contains the components of the steam-condensate-feed water-cycle, including the turbine and generator set. The Turbine Building is independent of the Nuclear Island such that internal hazards in the Turbine Building remain confined. The building is located in a radial position with respect to the Reactor Building to provide protection from turbine missile impact.

**2.2.2 EPR™ Nuclear Systems**

The EPR™ nuclear systems are mainly located in the Reactor Building, Fuel Building and Safeguard Buildings. These buildings are robust and shielded where necessary to ensure all radioactive substances are always secure. Systems include:

- Reactor Coolant System.
- Fuel handling and storage system.
- Shut-down and reactivity control systems
- Emergency Core Cooling systems, Containment cooling system, Chemical and Volume Control System, In-Containment Refuelling Water Storage Tank.

The systems are described below.



**2.2.3 Reactor Coolant System**

*General Characteristics*

The Reactor Pressure Vessel (RPV) is located at the centre of the Reactor Building and contains the core with fuel assemblies. The reactor coolant flows through the hot leg pipes to the SGs and returns to the RPV via the cold leg pipes by the RCPs. The PZR is connected to one hot leg via the surge line and to two cold legs by the spray lines.

{A description of the Reactor Coolant System can be found in Chapter 5 of UK EPR Pre-Construction Safety Report}.

*Reactor Pressure Vessel*

The RPV is the main component of the RCS. The vessel is cylindrical, with a welded hemispherical bottom and a removable flanged hemispherical upper head with gasket. It contains the reactor core, the control rods, the neutron shield, and the supporting and flow-directing internals. See Figure 4

The RPV is made of low-alloy steel with the complete internal surface covered by stainless steel cladding for corrosion resistance. Coolant from the cold legs enters the vessel through the inlet nozzles and flows down through the annulus between the core barrel and the reactor vessel inner wall. At the bottom of the vessel, the coolant streams from the four cold legs are combined in a flow mixing device and then passed up through the core where it is heated. It then flows through the RPV outlet nozzles into the hot legs and toward the SGs.

The RPV closure head is provided with penetrations for Control Rod Drive Mechanisms, in-core instrumentation, level measurement, dome temperature and venting pipes.

The entire structure of the RPV is supported to ensure it is capable of withstanding the forces caused by design basis and severe accidents, as well as seismic events.

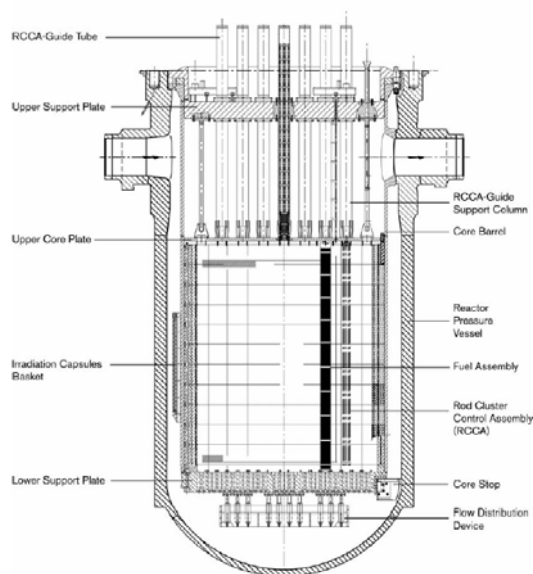

*Figure 4: Reactor Pressure Vessel and Internals*

[{A description of the EPR™ Reactor Pressure Vessel can be found in Sub-chapter 5.3 of UK EPR Pre-Construction Safety Report}.](#)

#### *Pressuriser*

The PZR provides RCS pressure control and also serves as the coolant expansion vessel of the RCS (the RCS volume being controlled by the Chemical and Volume Control System); it consists of a vertical cylindrical shell closed at both ends by hemispherical heads.

The spray system inside the PZR consists of main spray and auxiliary spray nozzles. The main spray lines are connected to cold legs, whilst the auxiliary spray line is connected to the Chemical and Volume Control System (CVCS).

The PZR is equipped with electric heater rods. Its upper head has four large nozzles, one for each of the three safety valve connections and one for the Pressuriser Depressurisation System (PDS) line used for severe accident mitigation. It also has one small nozzle for venting. The PZR is connected to the RCS by a surge line that connects to one hot leg and by two smaller diameter spray lines which connect to separate cold legs.

[{A description of the Pressuriser can be found in Sub-chapter 5.4 of the UK EPR Pre-Construction Safety Report}.](#)

#### *Steam Generators*

The SGs are vertical shell, natural circulation, U-tube heat exchangers with integral moisture separating devices. Figure 5 shows a cutaway view of the SG.

The reactor coolant flows through the inverted U-tubes, entering and leaving nozzles located in the hemispherical bottom channel head of the SG. The heat conveyed by the reactor coolant is transferred to the secondary fluid through the tube walls of the tube bundle. On the secondary side, the feedwater is directed to the cold side of the tube sheet by an annular skirt in which feedwater is injected by the feedwater distribution ring.

This design enhances the heat exchange efficiency between the primary side and the secondary side. The tube material is Inconel 690, which is highly resistant to corrosion.

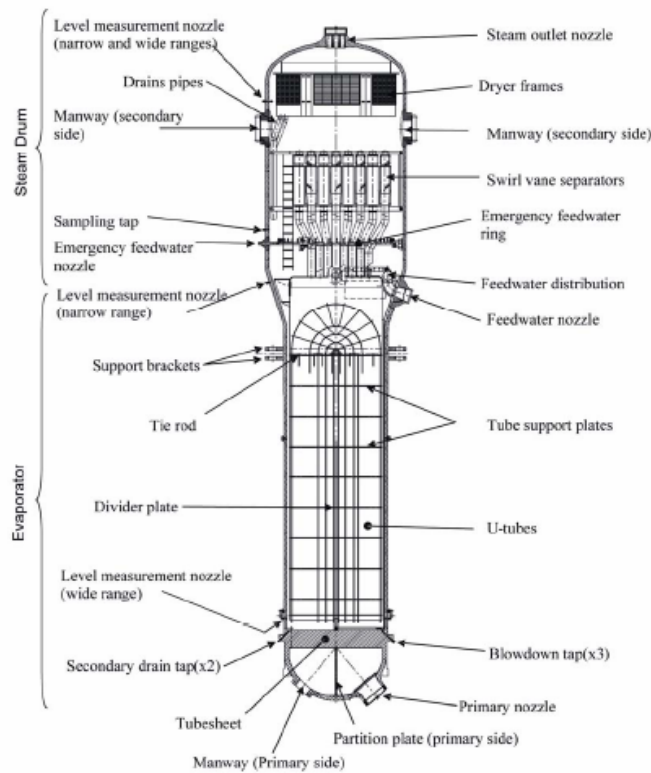

*Figure 5 – Steam Generator*

{A description of the Steam Generators can be found in Sub-chapter 5.4 of the UK EPR Pre-Construction Safety Report}.

*Reactor Coolant Pumps*

The RCPs are vertical, single-stage, shaft seal units, driven by air-cooled, three-phase induction motors. The complete unit is a vertical assembly consisting of (from top to bottom) a motor, a seal assembly, and a hydraulic unit. The shaft seals are equipped with a Standstill Seal System (SSSS) to prevent leakage.

{A description of the Reactor Coolant Pumps can be found in Sub-chapter 5.4 of the UK EPR Pre-Construction Safety Report}.

*Reactor Coolant Piping*

The reactor coolant piping in each of the four coolant loops consists of a hot leg, a crossover leg, and a cold leg. The hot leg extends from the RPV to the SG; the crossover leg from the SG to the RCP; and the cold leg from the RCP to the RPV.

The design of the reactor coolant system, the use of forged pipework and components, construction with high mechanical performance materials, combined with the measures to allow early leak detection and to promote in-service inspections, allows rupture of the major reactor coolant pipework to be excluded from the design basis.

{A description of the Reactor Coolant Piping can be found in Sub-chapter 5.4 of the UK EPR Pre-Construction Safety Report}.

## 2.2.4 Reactor Core

The reactor core contains the fuel in which the fission reaction takes place, releasing energy. The reactor internal structures support the fuel assemblies, channel the coolant and guide the control rods which control the fission reaction. The core is cooled and moderated by water at a pressure of approximately 155 bar and a temperature in the range of 300°C. The coolant contains soluble boron as a neutron absorber. The boron concentration in the coolant is varied as required to control relatively slow reactivity changes, including the effects of fuel burn-up.

Additional neutron absorbers (gadolinium), in the form of burnable absorber-bearing fuel rods, are used to adjust the initial reactivity and power distribution. Instrumentation is located inside and outside the core to monitor its nuclear and thermal-hydraulic performance and to provide input for control, limitation and protection functions. The main features of the core and its operating conditions have been selected to obtain not only high thermal efficiency, but also extended flexibility for different fuel cycle lengths and an enhanced capability to perform load following.

[{A description of the Reactor Core design can be found in Chapter 4 of the UK EPR Pre-Construction Safety Report}.](#)

### *Fuel and Fuel Management*

The reactor core consists of an array of 241 fuel assemblies and is able to accommodate the well established 17x17 fuel assembly design. The fuel rods consist of uranium dioxide pellets stacked in a cladding tube plugged and seal welded to encapsulate the fuel. Uranium enrichments up to 5% U235 are considered. The core is also designed to allow the use of MOX (uranium plus plutonium oxide) fuel.

The EPR™ fuel design benefits from many years of experience; each feature is currently in use in operating reactors. Thus there is high confidence in the fuel integrity and a detailed understanding of its performance borne out by the exceptionally low proportion of fuel rod failures observed. Even in the event of fuel damage, mechanical integrity is not lost and the fuel is retained within the cladding.

The low core power density allows flexibility in fuel cycle length between 1 and 2 years, with an efficient use of the fuel as the size of the reload is kept below one half of the core for 2-year fuel cycle. For 18-month fuel cycle the need for natural uranium is limited to about 20 te/TWhe.

[{A description of the Fuel design and the proposed Fuel Management scheme can be found in Chapter 4 of the UK EPR Pre-Construction Safety Report}.](#)

### *Core Instrumentation (See Figure 6)*

The core nuclear power level is measured using a primary heat balance and by neutron flux measurements from the ex-core instrumentation, which is also utilised to monitor the occurrence of criticality and detect power imbalances between core quadrants.

The reference instrumentation used to periodically establish the power distribution in the core is the "Aeroball" system, in which vanadium alloy steel balls are briefly inserted in the core. Activation measurements then allow the determination of local neutron fluxes which are used to construct a three-dimensional power map of the core.

The fixed in-core instrumentation consists of neutron detectors used to continuously measure the neutron flux distribution in the core, and thermocouples used mainly for measuring the margin-to-saturation in post-accident or degraded thermal-hydraulic conditions.

{A description of the Core Instrumentation can be found in Sub-chapter 4.4 of the UK EPR Pre-Construction Safety Report}.

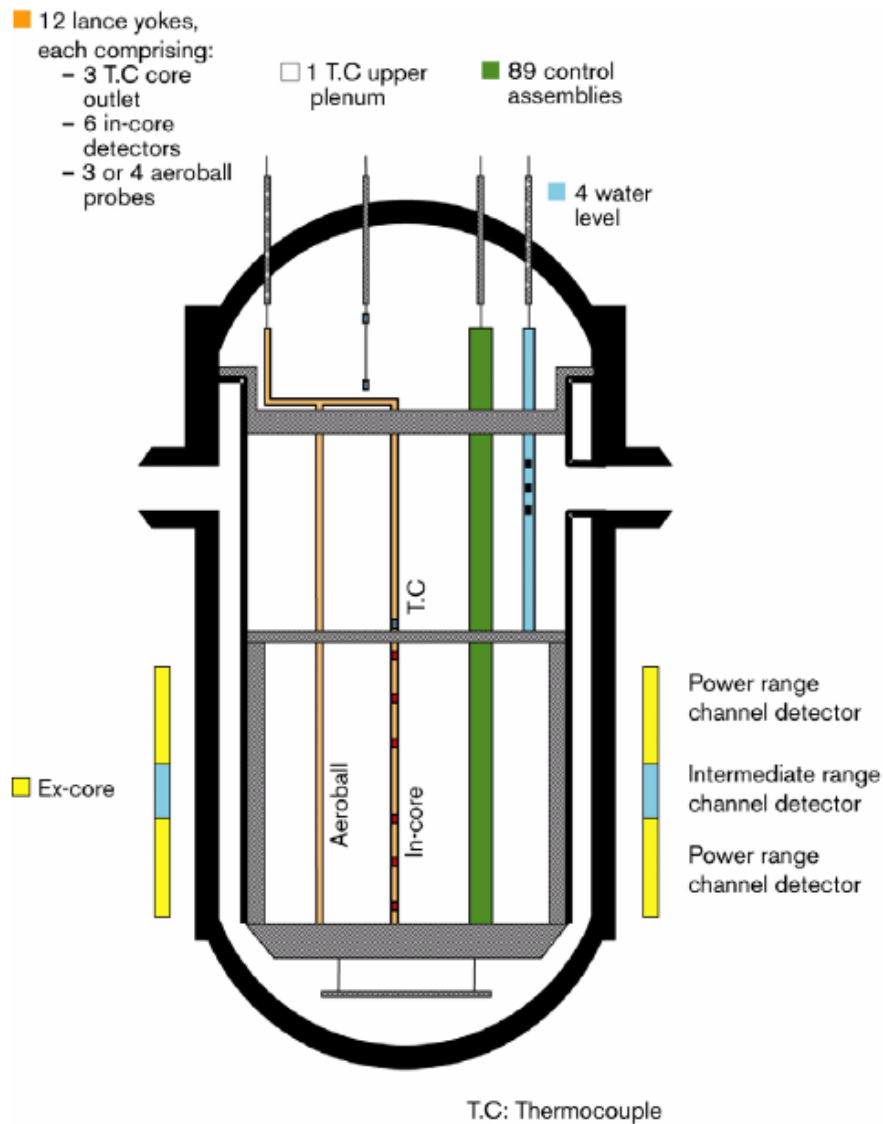

Figure 6: Reactor Core – In-Core and Ex-Core Instrumentation

*Fuel Handling System*

The reactor core is periodically reloaded with fresh fuel assemblies. The spent fuel assemblies are moved to and stored in the Spent Fuel Pool. Underwater fuel storage racks are used for storage of fresh and spent fuel assemblies (note that a dry rack is also available for new fuel storage only). The pool capacity allows the spent fuel from at least 10 years of operation to be stored prior to export.

{A description of the Fuel Handling System can be found in Sub-chapter 9.1 of the UK EPR Pre-Construction Safety Report}.

### 2.2.5 Systems

Safety systems and functions have been designed according to the following principles:

- Simplification by separation of operational and safety functions.
- Fourfold redundancy in the safeguard systems and their support systems. This allows them to be maintained during plant operation, ensuring a high plant availability factor.
- Strict physical separation between buildings where the different trains of the safety systems are located.
- Application of systematic functional diversity; there is always a diverse system which can perform the desired function and bring the plant back to a safe condition in the highly unlikely event of all the redundant trains of a system becoming totally unavailable.

#### *Chemical and Volume Control*

The Chemical and Volume Control System (CVCS) is the interface system between the high pressure RCS and the low pressure systems in the Nuclear Auxiliary Building and Fuel Building. The CVCS provides a flow path for the continuous letdown and charging of RCS water. It maintains the RCS water inventory at the desired level and allows adjustment of the soluble boron concentration.

[{A description of the Chemical and Volume Control System can be found in Sub-chapter 9.3 of the UK EPR Pre-Construction Safety Report}.](#)

#### *Safety Injection / Residual Heat Removal*

The Safety Injection System (SIS/RHRS) performs a dual function being used both in normal operating conditions (in RHR mode) and in the event of an accident.

During normal operating conditions, operating in RHR mode, the system:

- provides the capability for heat transfer from the RCS to the Component Cooling Water System (CCWS),
- transfers heat continuously from the RCS or the reactor refuelling pool to the CCWS during cold shutdowns and shutdown for refuelling.

In the event of an assumed accident the SIS, operating in RHR mode in conjunction with the CCWS and the Essential Service Water System (ESWS), maintains the RCS core outlet and hot leg temperatures below 180°C following a reactor shutdown.

In safety injection mode, the main function of the SIS is to inject water into the reactor core following a postulated loss of coolant accident in order to compensate for the consequence of such events.

[{A description of the Safety Injection /Residual Heat Removal System can be found in Sub-chapter 6.3 of the UK EPR Pre-Construction Safety Report}.](#)

#### *In-Containment Refuelling Water Storage Tank*

The IRWST is a tank containing a large volume of borated water to fill the reactor cavity, the internal storage compartment, the reactor building transfer compartment during refuelling. It is able to collect water discharged inside the containment in postulated accident conditions. Its main function under fault conditions is to supply water to the SIS, Containment Heat Removal System (CHRS) and Chemical and Volume Control System (CVCS) pumps, and to flood the corium spreading area in the event of a hypothetical core melt accident.

{A description of the In-Containment Refuelling Water Storage Tank can be found in Sub-chapter 6.3 of the UK EPR Pre-Construction Safety Report}.

#### *Emergency Feedwater*

The Emergency Feedwater System (EFWS) ensures that water is supplied to the steam generators when all other feedwater supply systems are unavailable.

{A description of the Emergency Feedwater System can be found in Sub-chapter 6.6 of the UK EPR Pre-Construction Safety Report}.

#### *Other Safety Systems*

The Extra Boration System (EBS) ensures sufficient boration of the RCS for transfer to the safe shutdown state at a boron concentration required for cold shutdown. This system consists of two separate and independent trains, each capable of injecting the total amount of concentrated boric acid required to reach the cold shutdown condition from any steady state power operating state.

Moreover, in the highly unlikely event of an accident combined with unavailability of the reactor trip, the EBS ensures fast automatic boration of the RCS.

{A description of the Extra Boration System can be found in Sub-chapter 6.7 of the UK EPR Pre-Construction Safety Report}.

Parts of the Main Steam System (MSS) and of the Main Feedwater System (MFWS) are also safety classified.

{A description of safety classified part of the Main Steam System can be found in Sub-chapter 10.3 of the UK EPR Pre-Construction Safety Report}.

{A description of safety classified part of the Main Feedwater System can be found in Sub-chapter 10.6 of the UK EPR Pre-Construction Safety Report}.

#### *Component Cooling Water*

The Component Cooling Water System (CCWS) transfers heat from the safety-related systems, operational auxiliary systems and other reactor equipment to the ultimate heat sink via the Essential Service Water System (ESWS).

{A description of the Component Cooling Water System can be found in Sub-chapter 9.2 of the UK EPR Pre-Construction Safety Report}.

### *Ultimate Cooling Water System*

The Ultimate Cooling Water System (UCWS) is a diverse system allowing the dedicated cooling system associated with the mitigation of postulated severe accidents to be cooled, or to act as a back up for cooling the fuel pool.

[{A description of the Ultimate Cooling Water System can be found in Sub-chapter 9.2 of the UK EPR Pre-Construction Safety Report}.](#)

### *Other Systems*

Other systems include:

- The Nuclear Sampling System used for taking samples of gases and liquid from systems and equipment located inside the reactor containment  
[{A description of the Nuclear Sampling System can be found in Sub-chapter 9.2 of the UK EPR Pre-Construction Safety Report}.](#)
- The Vent and Drain System for collecting gaseous and liquid waste from systems and equipment for treatment  
[{A description of the Vent and Drain System can be found in Chapter 11 of the UK EPR Pre-Construction Safety Report}.](#)
- The Steam Generator Blowdown System which prevents build-up of solid matter in the secondary side water  
[{A description of the Steam Generator Blowdown System can be found in Sub-chapter 10.4 of the UK EPR Pre-Construction Safety Report}.](#)
- Waste Treatment Systems for the treatment of solid, gaseous and liquid wastes  
[{A description of the Waste Treatment Systems can be found in Chapter 11 of the UK EPR Pre-Construction Safety Report}.](#)

The design of the EPR™ fire protection system is based on the concept of defence in depth and is focused on protecting the safety of the public, the environment, and plant personnel from a fire and its potential effect on safe reactor operations.

[{A description of the Fire Protection System can be found in Sub-chapter 9.5 of the UK EPR Pre-Construction Safety Report}.](#)

The Heating, Ventilation and Air Conditioning Systems (HVAC) function is to contain radioactive substances and reduce radioactive releases to the environment and to maintain ambient conditions for equipment and personnel.

[{A description of the Heating, Ventilation and Air Conditioning Systems can be found in Sub-chapter 9.4 of the UK EPR Pre-Construction Safety Report}.](#)

The main systems are shown in Figure 7.



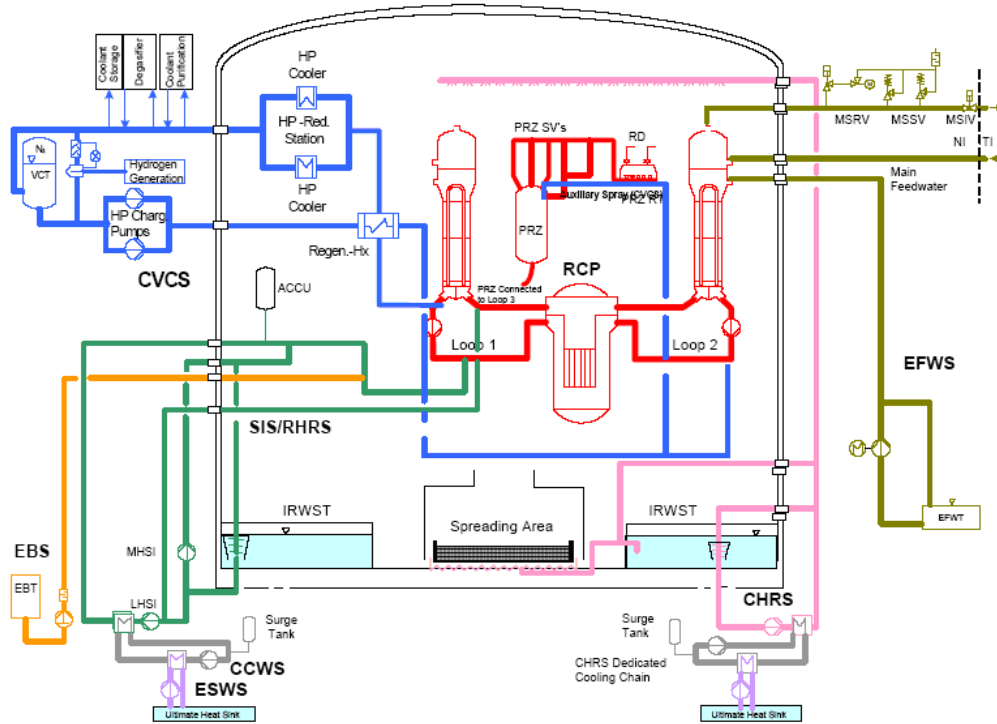

Figure 7: Main Fluid Systems

**2.2.6 Instrumentation & Control System**

The plant instrumentation and control (I&C) system, which comprises several systems and their electrical and electronic equipment, is made up of sensors to transform physical data into electrical signals, programmable controllers to process these signals, and the control actuators, monitors and other means of control by plant operators.

The EPR™ I&C system is computerised and supported by modern digital technologies to provide operational flexibility. Well proven technology is used for safety-related applications, and a diverse technology applied for standard plant controls that is validated through use on industrial plants throughout the world.

The I&C systems and equipment comply with the principles of redundancy, divisionalisation and diversity applied to all of the EPR™ safety-related systems.

{A description of the I&C systems can be found in Chapter 7 of the UK EPR Pre-Construction Safety Report}.

To operate and monitor the plant the operators use workstations and a plant overview panel in the Main Control Room. In the event of a failure of the workstation, plant operation is ensured via a backup panel; in case of unavailability of the Main Control Room, the plant is monitored and controlled from the Remote Shutdown Station.

{A description of the Main Control Room and the Remote Shutdown Station can be found in Sub-chapter 18.1 of the UK EPR Pre-Construction Safety Report}.

### **2.2.7 Electrical Power System**

The basic power supply for the EPR™ plant operates at 50 Hz, with voltage regulated by on-load tap changers through a site/utility specific transmission grid. The Electrical Distribution System (EDS) is designed as a 4-train, 4-division system.

The Emergency Power Supply System (EPSS) of the EDS is designed to ensure that the safety systems, required to safely shut down the reactor, remove residual and stored heat, and prevent the release of radioactivity, are supplied with electrical power in the event of loss of the preferred electrical sources. Each train is provided with an Emergency Diesel Generator (EDG) set. In the event of total loss of the four EDGs, two additional and diverse generators, the Station Black-Out (SBO) Diesel Generators, provide the power necessary to supply the respective emergency loads.

[{A description of the Electrical Power System can be found in Chapter 8 of the UK EPR Pre-Construction Safety Report}.](#)

## **3. NUCLEAR SAFETY**

### **3.1 SAFETY DESIGN**

The fission of atomic nuclei, which takes place in a nuclear reactor to generate heat, produces large quantities of radioactive substances from which people and the environment must be protected.

Nuclear safety is the set of technical and organisational provisions that are applied in the design, construction and operation of a nuclear plant to reduce the likelihood of an accident and to limit its consequences in the unlikely event that it did occur.

Nuclear reactor safety requires that at all times three basic safety functions should be fulfilled:

- control of the nuclear chain reaction, and therefore of the power generated,
- cooling of the fuel, including removal of residual heat after the chain reaction has stopped,
- containment of radioactive products.

### **3.2 DEFENCE-IN-DEPTH**

Nuclear safety relies upon two main principles:

- the availability of three protective barriers,
- application of defence in depth.

#### *Three Protective Barriers*

The concept of the “protective barriers”, see Figure 8, involves placing a series of strong, leak-tight physical barriers between the radioactive materials and the environment to contain radioactivity in all circumstances:

- first barrier: the fuel, inside which most of the radioactive products are already trapped, is enclosed within a metal cladding;
- second barrier: the reactor coolant system is enclosed within a pressurised metal envelope that includes the reactor vessel which houses the core containing the fuel rods;
- third barrier: the reactor coolant system is itself enclosed in a containment building (for the EPR™ reactor, the containment is a double shell resting on a thick basemat, the inner wall of the first shell being covered with a leak-tight metallic liner).

**The three protective barriers**

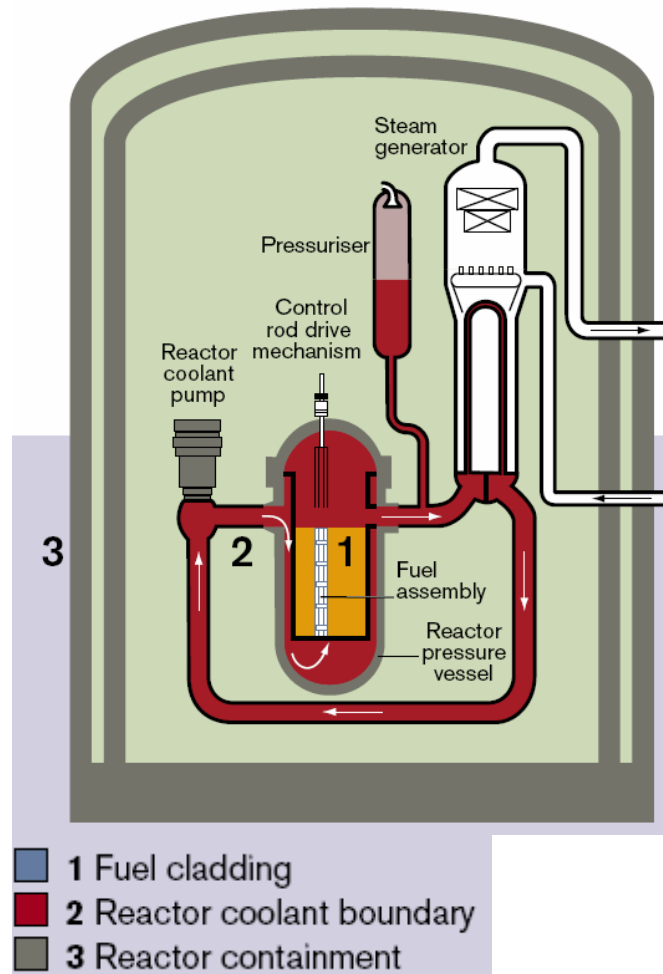

*Figure 8: The Three Protective Barriers*

{The concept of protective barriers is explained in Sub-chapter 3.1 of the UK EPR Pre-Construction Safety Report}.

*Defence in Depth*

The concept of “defence in depth” involves ensuring the effectiveness of the protective barriers by identifying the threats to their integrity and by providing successive lines of defence to protect them from failure:

- first level: the implementation of a safe design, high quality of construction and safe and reliable operation incorporating lessons from experience to prevent occurrence of failures;
- second level: effective surveillance for detecting anomalies that could lead to a departure from normal operating conditions, in order to anticipate failures or to detect them as soon as they occur;
- third level: arrangements for mitigating the consequences of failures and preventing core melt down. This level includes use of diverse and redundant systems to automatically bring the reactor to a safe shutdown state. The most important of these is the system that automatically shuts down the reactor by insertion of the control rods into the core, stopping the nuclear chain reaction in a few seconds. In addition, a set of safeguard systems, which also have redundancy, are provided to ensure the containment of radioactive products.

To further extend the defence in depth approach a failure of all three levels is postulated, resulting in a “severe accident” situation. As the fourth level of defence, means are provided to minimise the consequences of such a situation.

[{The application of the defence-in depth concept to the EPR™ design is explained in Sub-chapter 3.1 of the UK EPR Pre-Construction Safety Report}.](#)

### 3.3 SAFETY ANALYSIS

As with previous PWRs, the effectiveness of the ‘third level’ safety systems designed to prevent core melt is demonstrated by analysis of a range of postulated upset conditions (transients, incidents and accidents) that could potentially result in core damage. The EPR™ safety case contains a comprehensive analysis of these design basis plant conditions (referred to as Plant Condition Categories – PCCs), using validated computer models.

[{A summary of the design basis plant conditions is presented in Sub-chapter 14.0 of the UK EPR Pre-Construction Safety Report}.](#)

In accordance with the recommendations of the French and German safety authorities, the EPR™ design is based on an evolutionary approach using experience feedback from previous PWRs, particularly from the most recently constructed plants (N4 reactors in France and KONVOI in Germany), largely avoiding the risk from the adoption of unproven technologies.

However innovative design solutions, backed by the results of large-scale Research and Development programmes, were not completely excluded. Key innovations have been included in the EPR™ design to help accomplish EPR™ safety objectives, in particular with regard to the prevention and mitigation of hypothetical severe (core melt) accidents.

The EPR™ safety approach, motivated by a desire to achieve improved safety levels, involves a reinforced application of the defence in depth concept:

- by improving preventive measures to reduce the probability of core melt,
- by incorporating features for limiting the consequences of core melt accidents at the design stage.

[{The application of the defence-in depth concept to the EPR™ design is explained in Sub-chapter 3.1 of the UK EPR Pre-Construction Safety Report}.](#)

*Design Choices for Reducing the Probability of Accidents that could cause Core Melt*

In order to reduce the probability of core melt accidents, below the low levels already achieved in reactors in the French and German nuclear power plants fleet, improvements were made in three areas:

- an extended range of operating conditions was taken into account at the design stage,
- equipment and systems were designed to reduce the likelihood of an abnormal situation deteriorating into a severe accident,
- improvements were made in the reliability of operator actions.

Although the EPR™ safety approach is based mainly on the deterministic application of the defence in depth concept, the design is supported by probabilistic analyses. These make it possible to identify accident sequences that could cause core melt or result in significant radioactivity releases, to evaluate their probability, and to identify their potential causes and countermeasures. The use of Probabilistic Safety Assessment (PSA) at the design phase of the EPR™ reactor has been a decisive factor in the choice of technical options to improve the safety level of the reactor.

For the EPR™ design, the probability of an accident leading to core melt meets the target set by the EUR for accident frequency. Probabilistic Safety Assessment for the UK EPR™ design shows that the UK HSE Basic Safety Objectives for the risk to individuals and societal risk are also met.

[{A summary of the scope of the Probabilistic Safety Assessment for the UK EPR™ reactor can be found in Sub-chapter 15.0 of the UK EPR Pre-Construction Safety Report}.](#)

The design of the safeguard systems and civil works structures minimises the risks from hazards (earthquake, flooding, fire, aircraft crash). The safeguard systems are designed on the basis of a quadruple redundancy, both in their mechanical and electrical design and in the design of the supporting I&C. This means that each system consists of four subsystems, or “trains”, each one capable by itself of fulfilling the entire safeguard function. The four redundant trains are physically separated from each other and located in four independent divisions (buildings).

Each division includes one train of:

- the safety injection system for injecting borated water into the reactor vessel in a loss of coolant accident,
- the steam generator emergency feedwater system,
- the electrical and I&C systems supporting these systems.

The building housing the reactor, the building in which the spent fuel is stored on an interim basis, and the four buildings corresponding to the four divisions of the safeguard system are provided with special protection against externally-generated hazards such as earthquakes and explosions.

Protection against an aircraft crash has been further strengthened. The reactor building is protected by a double concrete shell: an outer thick shell made of reinforced concrete and an inner thick shell made of pre-stressed concrete which is internally covered with a thick metallic liner. The thickness and the reinforcement of the outer shell provide sufficient strength to absorb the impact of a large commercial aircraft. The double concrete wall protective shell is extended to the fuel building, and to two of the four safeguard buildings containing the Main Control Room and the Remote Shutdown Station which would be used in emergency conditions.

The other two safeguard buildings which are not protected by the double wall shell are remote from each other and separated by the reactor building, which prevents them from being simultaneously damaged. In this way, if an aircraft crash were to occur, at least three of the four trains of the safeguard systems would be protected.

[{Details of the principles of the design of the EPR™ plant to protect against internal and external hazards can be found in Chapter 13 of the UK EPR Pre-Construction Safety Report}.](#)

#### *Design Choices for Limiting the Consequences of Severe Accidents*

New safety requirements for future nuclear power plants, introduced as early as 1993 by the French and German safety authorities, required that the plant was designed so even if a core melt accident were to occur, there would be only very limited effects outside the reactor site.

The policy of mitigation of the consequences of a severe accident, which guided the design of the EPR™ plant, therefore aimed to 'practically eliminate' situations which could lead to early radiological releases, such as:

- high-pressure core melt ejection from the reactor pressure vessel,
- high-energy corium/water interactions,
- hydrogen detonations inside the reactor containment,
- by-pass of the containment.

Moreover, the integrity of the reactor containment, even in the event of a low-pressure core melt followed by ex-vessel progression, is ensured through:

- retention and stabilisation of the molten corium inside the containment,
- cooling of the corium.

### **3.4 DOSE TARGETS AND LEGAL LIMITS**

In the UK, like in France, the Legal Limits for doses to the public and workers are the same as the ICRP recommendations for a reactor during normal operation. Lower Basic Safety Limits are prescribed by the UK HSE for doses to worker groups exposed to radiation. Based on operating experience from similar French and German plants these limits will be comfortably met by the EPR™ reactor.

[{Protection of workers against risks from radiation is described Chapter 12 of the UK EPR Pre-Construction Safety Report}.](#)

The EPR™ plant has a collective dose target of 350man mSv/year (normal operation) which is a small fraction of the dose target adopted for earlier generation PWRs such as the UK Sizewell B PWR. An assessment of worker collective dose due to EPR™ operation and maintenance shows that the collective dose target is likely to be achieved.

[{An assessment of workers collective radiation dose is given in Sub-chapter 12.4 of the UK EPR Pre-Construction Safety Report}.](#)

An assessment of the annual dose to the most exposed members of the public off-site due to operation of an EPR™ reactor in the UK has been performed using pessimistic methods applied by the UK Environment Agency and conservative UK site parameters. Results give an estimated a total annual dose of 26 µSv. This is well below UK government limit for a nuclear power station (single unit site) of 300 µSv.

[{An analysis of off-site radiological impact due to normal operation of the UK EPR™ reactor can be found in Chapter 11 of the UK EPR Pre-Construction Environmental Report}.](#)

Additional probabilistic ranges and Basic Safety Objectives for doses to the public due to accidents are specified in the UK by the HSE. PSA modelling has been used to assess the UK EPR™ design against these targets for a plant located on the 'worst case' existing UK nuclear site. The results show that the EPR™ design complies with the HSE Basic Safety Objectives in all cases.

## **4. OPERATION AND MAINTENANCE**

### **4.1 NORMAL OPERATION**

Normal operation comprises:

- power operation and normal scheduled operating transients such as increases in load, reductions in load, load following, unit shutdown or start-up,
- specific operations due to unplanned events, such as house load operations or loss of power sources for example.

The EPR™ reactor performance relative to load following is in line with the EUR goals for performing both large daily or weekly load adjustment and frequent and fine power changes in order to contribute to grid frequency control.

[{EPR™ capability for load following is described in Sub-chapter 1.2 of the UK EPR Pre-Construction Safety Report}.](#)

### **4.2 PREVENTIVE MAINTENANCE**

Preventative maintenance includes inspections, tests, maintenance, repairs and replacements aimed at reducing the frequency and occurrence of equipment failure.

The aim is to ensure that, throughout the installation's service life, the objectives of nuclear and industrial safety, environmental protection, security, availability and cost are achieved.

The scope of preventive maintenance needs to take account of:

- safety objectives
- dose uptake,
- the target of over 90% plant availability

The general layout of the equipment has been planned to facilitate maintenance operation, thereby also improving industrial safety considerations. The short outage duration targets are based on the outage duration experience of the KONVOI plants that are used as the reference design for the EPR™ outage features.

[{The principles for preventive maintenance are described in Sub-chapter 18.2 of the UK EPR Pre-Construction Safety Report}.](#)

## 5. SPENT FUEL AND RADIOACTIVE WASTE MANAGEMENT INCLUDING DECOMMISSIONING

The management of radioactive waste is taken into account and optimised over the whole life cycle of the plant, i.e. design, operation, dismantling and decommissioning.

The design of the high performance core of the EPR™ reactor gives the operator increased flexibility in the utilisation of nuclear fuel to generate power. Depending on the fuel management strategy adopted and on the relevant point of comparison, there would be savings on uranium consumption per unit of energy produced up to 15%, giving a corresponding reduction in the quantities of higher-level waste.

Environmental impact of operations arises from the gaseous and liquid releases, and solid wastes produced. The evolutionary character of the EPR™ design makes it possible to draw benefit from lessons learned from many years of operation of earlier generation reactors, meaning that whenever possible, releases and waste are reduced and, when this is not possible, the extent and impact of such releases can be accurately predicted.

### *Gaseous Discharges*

Gaseous discharges from an EPR™ plant arise from the ventilation of the nuclear buildings and the degassing of radioactive fluids.

Depending on its origin, the gaseous discharge is:

- either filtered (filtration allows retention of more than 99% of aerosols and iodine and their conversion into solid waste.) and released into the atmosphere via the discharge stack. This is generally the case for gaseous waste coming from ventilation circuits;
- or retained in the treatment system to reduce the level of radioactivity and then filtered and released into the atmosphere via the discharge stack. This is the case for gases released by the degassing of primary cooling water.

{The source and routes of gaseous discharges are described in Sub-chapter 6.2 of the UK EPR Pre-Construction Environmental Report}.

{The gaseous treatment system is described in Sub-chapter 6.4 of the UK EPR Pre-Construction Environmental Report}.

In all circumstances, gaseous releases are controlled and monitored at the stack in order to check that these discharges do not have a noticeable impact on the terrestrial environment.

{Estimates of gaseous discharges to the environment are presented in Sub-chapter 6.3 of the UK EPR Pre-Construction Environmental Report}.

### *Liquid Discharges*

Liquid discharges from the EPR™ plant are placed in two categories depending on their origin:

- effluents from the primary system, which contains activation products, minor quantities of dissolved fission gases, fission products and chemical substances such as boric acid and lithium hydroxide. The chemical substances are almost all recirculated;



- effluents from the systems connected to the primary system. Among these, there are:
  - effluents which are radioactive and free from chemical pollution,
  - radioactive and chemically contaminated effluents, effluents with a very low level of radioactivity collected by the floor drains.

The systems and equipment used to treat and store radioactive liquid effluent help limit the radioactivity which is eventually released into the environment when discharged; much of the activity is retained in evaporator concentrates which are processed into solid waste. The effluent storage tanks undergo both radioactive and chemical sampling before being discharged.

{The source and routes for the liquid discharges are described in Sub-chapter 6.2 of the UK EPR Pre-Construction Environmental Report}.

{Estimates of gaseous discharges to the environment are presented in Sub-chapter 6.3 of the UK EPR Pre-Construction Environmental Report}.

{The systems used in the management of liquid discharges are described in Sub-chapter 6.4 of the UK EPR Pre-Construction Environmental Report}.

{An evaluation of the off-site collective dose due to normal operation of the UK EPR™ reactor can be found in Sub-chapter 11.1 of the UK EPR Pre-Construction Environmental Report}.

#### *Solid Radioactive Waste*

In addition to the evaporator concentrates, solid radioactive wastes arise from the spent resins, filters, maintenance and sundry activities that produce mostly low level waste. Reduction in the volume of solid radioactive waste to lessen the unit's impact on the environment was one of the objectives adopted at the design stage.

The operator waste treatment strategy and level of treatment determined as optimum under UK regulation will affect the volume of solid waste generated. However, using reasonable assumptions, the production of solid waste would be approximately 80 m<sup>3</sup> per year per unit (the majority of which will be LLW). This is consistent with comparable reactors around the world.

It is likely that most solid LLW operating waste would be conditioned in drums or containers for dispatch to the UK LLW repository. ILW operating waste would be conditioned for interim storage (on site in a facility capable of receiving up to 60 years worth of waste if necessary) pending disposal once such a facility becomes available in UK. All solid waste produced should be able to be disposed of and present no significant issues compared to existing UK wastes.

{The management of solid radioactive wastes is described in Sub-chapter 6.2 of the UK EPR Pre-Construction Environmental Report}.

{Arrangements for interim storage and disposability of solid radioactive wastes are described in Sub-chapter 6.5 of the UK EPR Pre-Construction Environmental Report}.

*Spent Fuel*

On average, about 40 to 60 fuel assemblies (each with approximately 0.5 te of uranium) are needed every year depending on the fuel management strategy adopted. Spent fuel will be stored in the spent fuel pool and if necessary in a further interim storage facility pending a decision for either reprocessing or final deep geological disposal. The interim storage facilities would have the capacity to cover up to 60 years of operation of the nuclear unit (equivalent to approximately 1,500 te of uranium). For a wet interim storage option, the pool fuel racks would cover an area of approximately 250m<sup>2</sup>.

{The management of spent fuel is described in Sub-chapter 6.2 of the UK EPR Pre-Construction Environmental Report}.

{Arrangements for interim storage and disposability of spent fuel are described in Sub-chapter 6.5 of the UK EPR Pre-Construction Environmental Report}.

*Decommissioning*

On the basis of the experience feedback resulting from dismantling operations performed in various countries on first generation nuclear power plants, the EPR™ design includes various measures which minimise the volume of decommissioning radioactive waste. Refer to Section 6 for further details.

{Design aspects related to decommissioning and volumes of radwaste arising from decommissioning are described in Chapter 5 of the UK EPR Pre-Construction Environmental Report}.

{Options for the management of solid radioactive waste from operations and decommissioning and spent fuel are described in the Solid Radioactive Waste Strategy Report, NESH-G 2008 en 0123 A}

## **6. OTHER ENVIRONMENTAL IMPACTS**

{The different phases and activities that will take place during the UK EPR operation phase are summarised in Chapter 3 of the UK EPR Pre-Construction Environmental Report}.

These activities having potentially an impact on the environment during the operation phase because they either use natural resources or generate wastes and discharges are highlighted.

The diagram below illustrates the interfaces of the UK EPR with the environment, including water, air, and land compartments.

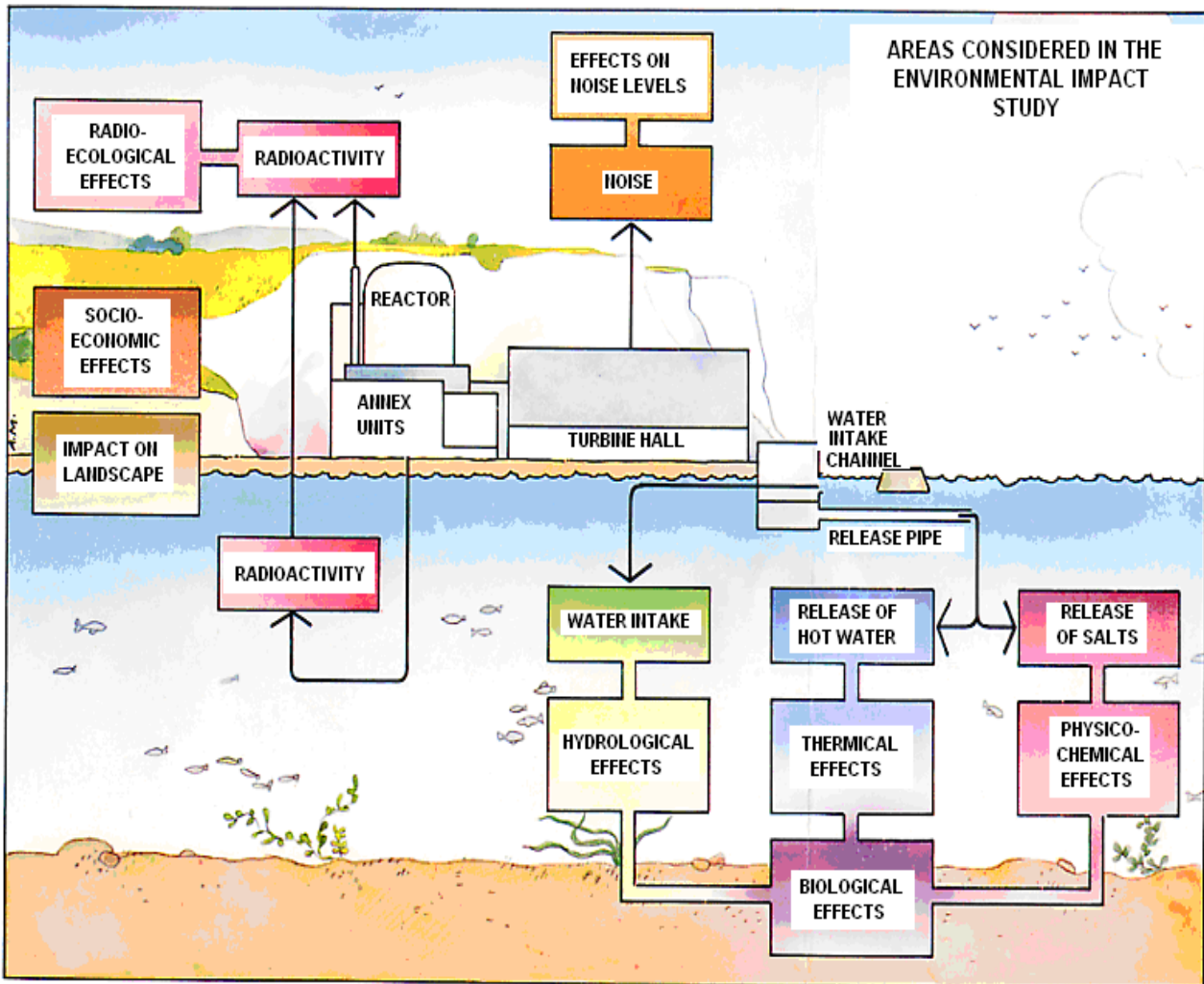

{The various activities that take place during the UK EPR construction phase and aspects that have a bearing on the terrestrial and aquatic environments are described in Chapter 4 of the UK EPR Pre-Construction Environmental Report}.

{Detailed information of the non-radiological impact during EPR™ construction and operation can be found in Chapter 12 of the UK EPR Pre-Construction Environmental Report}.

**6.1 IMPACTS ON TERRESTRIAL ECOSYSTEM**

- Impact on air quality and climate

With regards to air quality:

- During the construction phase, potential sources of gaseous non-radioactive emissions include chemical discharges (formaldehyde and carbon monoxide), dust emissions and exhaust emissions from vehicles movements. The formaldehyde and carbon monoxide emissions produced during this phase are unlikely to cause a significant impact on air quality. The impact of dust and exhaust emissions from vehicles movements will be assessed once the specific site will be selected.

- During the operation phase, the potential sources of gaseous non radioactive emissions include chemical discharges and exhaust emissions from vehicles movements. The impact of exhaust emissions will be assessed at the site specific stage.

Regarding chemical discharges, the following three main groups have been identified:

- Sulphur and nitrogen dioxides in the exhaust gases from engines in the backup electricity generators:

These generators are only likely to be used for a few hours per year for periodic tests. Exhaust emissions associated with these emissions are not considered to be significant and will be in accordance with necessary consents;

- Formaldehyde and carbon monoxide emitted by the insulation into the ventilation system which is discharged via the stack;
- Ammonia discharged as the temperature rises in the steam generators during startup.

These emissions are unlikely to cause a significant impact on air.

With regards to odour, there are potential sources of odorous emissions during construction and operation phases, but these emissions occur over short time periods. Consequently, it is unlikely that these emissions will lead to significant impact. If a situation arises where odour is a problem, appropriate assessment shall be carried out.

With regards to the climate, nuclear power generation has a relatively small carbon footprint as Nuclear Power Plants do not produce carbon dioxide directly from electricity generation. As a consequence, the UK EPR activities do not affect the climate.

- Noise and vibration impacts

During the construction phase, the adoption of a Construction Environmental Management Plan and operation in accordance to best practice will minimise noise disturbance to nearby noise-sensitive receptors as far as reasonably practicable. However, it is recognised that due to the nature of construction works, there is still the potential for a temporary adverse impact at nearby noise-sensitive receptors. However, this is considered to be of minor significance at worst.

During the operation phase, following the process control and monitoring stage of the development, the operation of the UK EPR should have a negligible impact on nearby noise-sensitive receptors. This will be validated via in situ measurements once the EPR unit is commissioned. The impact will be assessed once a specific site will be selected.

- Landscape and visual impacts

The construction and operation phases of the UK EPR can have the potential to impact the coastal landscape and its visibility, the key views and visual amenity. Visual effects result from changes in the landscape or seascape. They are defined as changes in the appearance of the landscape or seascape, and the effects of these changes on people. Different potential effects such as traffic impact and impact on cultural designations will be taken into account in the site-specific detailed assessment.

- Other impacts during the construction phase

As the impact assessment of works during the construction phase is strongly dependent of the site retained, the particular impacts of works (on topography, geology, fauna and flora) will be studied during the site specific phase.

## **6.2 IMPACTS ON AQUATIC ECOSYSTEM**

- Impact of water abstraction and thermal discharges

An EPR reactor can be cooled by an open cycle cooling system (heat rejected to sea or river-water) or by a closed cycle cooling system (heat rejected to atmosphere using cooling towers). For an EPR plant located on the coast using open cycle cooling, approximately 67 m<sup>3</sup>/s of water (for a temperature rise of 12°C) would be continuously required for cooling the unit. A detailed assessment of the impact of water abstraction and thermal discharges requires a site specific assessment to be carried out; nevertheless such impacts can be successfully minimised by site specific design features.

- Liquid non radioactive species impact

Chemicals discharged into the sea corresponding to the various activities on the construction site fall into two categories:

- Discharges associated with the preparatory work and the main building erection and the presence of staff on site. These discharges contain suspended solids, hydrocarbons and marine substances and have a five day biochemical oxygen demand
- Discharges associated with the start-up testing, which involves other chemicals required for the operation of the EPR.

The chemicals discharged into the sea during the EPR operation include:

- Chemical substances such as: boric acid, lithium hydroxide, hydrazine, morpholine, ethanolamine, phosphates, sodium, sulphates, bromoform, chlorides, iron;
- Mixtures of chemical substances: total metals and nitrogen, excluding hydrazine, morpholine and ethanolamine, and residual oxidants
- Physical-chemical characteristics: suspended solids, COD, BOD<sub>5</sub>, dispersants.

Assessments carried out for the GDA demonstrate that the impact on the receiving water can be considered as insignificant. At a site specific phase, a discharge consent will be obtained for any discharges to controlled waters for the construction and operation phases.

- Other impacts

As they are strongly dependent of the site specific environmental conditions, the particular impact of works during the construction phase, the impact of discharges on sedimentology and hydrogeology, the impact of potential dredging and the risk of flooding will be assessed at the site specific stage.

Structures, plant and machinery will be built to strict building control standards. Pollution Prevention and Control Regulations (PPC), regulatory specifications and Best Available Techniques (BAT) will minimise the potential for unplanned discharges to ground and to groundwater.

### **6.3 IMPACT ON DESIGNATED AREAS, SENSITIVE HABITATS AND PROTECTED SPECIES**

The impact of UK EPR activities on designated sites (SACs designated under the “Habitats Directive”, SPAs designated under the “Wild Birds Directive”, Ramsar sites designated under the Ramsar Convention and UK designated sites), on UK sensitive habitats and on UK protected species was assessed for an EPR plant located on a representative site.

The main results of the impact assessment indicate that there could be potential impacts on habitat integrity and protected species, direct and indirect, temporary (construction phase) and permanent (operation phase), particularly in coastal and near-shore marine environments as a result of construction and operation of a plant.

A programme of appropriate mitigation measures could be necessary to prevent or minimise significant impacts. Chief amongst them would be the preparation of a Management Plan, designed to manage and control the impact. A more detailed assessment of impacts on sensitive areas (habitats and species) will be carried out during the site specific phase.

### **6.4 IMPACT ON SOCIO-ECONOMICS**

The worksite and then the UK EPR operation represent an opportunity for socio-economic development. A detailed assessment of the socio-economic impacts will be assessed within the site specific application for consent.

## **7. DESCRIPTION OF SUBMISSION DOCUMENTS**

The GDA submission comprises the Safety, Security and Environmental Report (SSER) for the proposed UK EPR™ design, supplemented by a number of supporting documents, providing further information in a number of areas. The SSER itself comprises a Pre-Construction Safety Report (PCSR) containing nuclear safety aspects of the UK EPR™ design and a Pre-Construction Environmental Report (PCER) describing the environmental impact of the reactor, including both nuclear and non-nuclear discharges and waste production.

The PCSR presents a detailed description of the architecture of the UK EPR™ systems and components, their safety functions and reliability and availability requirements, and an explanation of the codes and standards that have been used in the design. The PCSR aims to demonstrate that sufficient analysis and engineering substantiation have been performed to give high confidence that the UK EPR™ design meets its declared safety objectives.

The PCER provides the information requested by the Environment Agency in its guidance Process and Information (P&I) Document for Generic Assessment of Candidate Nuclear Power Plant Designs, to allow their detailed assessment of the UK EPR™ environmental impact.

The supporting documents provide supplementary information to that provided in the SSER. The topics covered are largely in the waste and decommissioning topic area and include: waste and spent fuel management options; interim storage facilities for spent fuel and Intermediate Level Waste; decommissioning waste inventory; arrangements for monitoring of liquid and gaseous discharges; the longer term proposed storage facilities for Intermediate Level Waste and spent fuel; the EPR™ integrated waste strategy; and the application of Best Available Techniques. A comparison of the EPR™ design against the HSE/NII Safety Assessment Principles has also been provided.

The UK EPR™ GDA submission can be viewed on the EDF/AREVA UK EPR™ GDA website:

[{Link to EPR submission page of UK EPR GDA website}.](#)

A list of contents for each of the PCSR and PCER is available, together with a brief summary of each chapter and sub-chapter of these documents. A short summary of each of the supporting documents is also provided.

Each of the PCSR / PCER sub-chapters and the supporting documents can be downloaded in pdf format.

## **8. HOW TO FIND INFORMATION IN THE SUBMISSION**

Sections 2 and 3 of this document provide an overview of the UK EPR™ design and safety features.

Section 5 provides a summary of the issues concerning the management of radioactive waste, including spent fuel, over the life cycle of the plant.

Section 6 provides an outline of potential environmental risks from day-to-day operation of the EPR™ plant.

In each case, the text indicates where more detailed information can be found within the SSER, and a link is provided to the PCSR or PCER page of the EDF/AREVA UK EPR™ GDA website, as appropriate. Additionally, summaries of each chapter and sub-chapter provided on the website give an overview of the content of the SSER chapters and sub-chapters to aid navigation of the submission.

## **9. HOW TO COMMENT**

If you wish to comment on any aspect of the UK EPR™ GDA submission you may do so online at the EDF/AREVA UK EPR™ GDA website:

[{Link to comment page of UK EPR GDA website}.](#)

Your comment will be sent to the Joint Programme Office of the UK Nuclear Regulators, who are overseeing the Public Involvement Process.

If your comment is relevant to the UK EPR™ GDA submission, the Joint Programme Office will forward it to AREVA - EDF and you will receive a response within 30 days.